

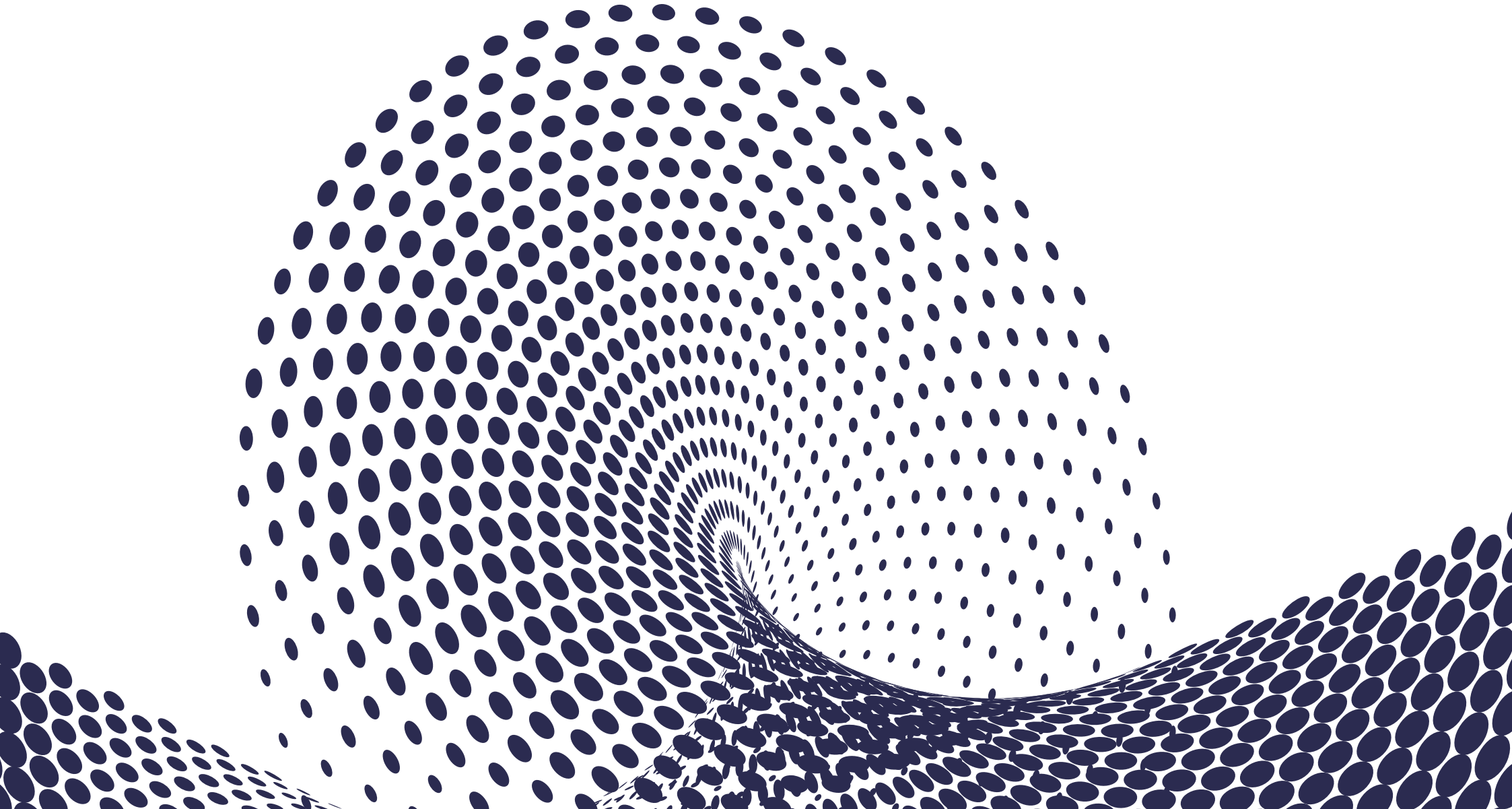

Instant Proces
Desarrollamos y envasamos su proyecto

www.instantproces.com



Desarrollo

Especializados en el desarrollo de formulaciones galénicas e industrialización del producto.

Certificaciones

Los productos que desarrollamos y/o fabricamos son aptos para la exportación y cumplen con la normativa GMP, ISO. 22.000, FDA, FSSC 22.000, CCPAE.

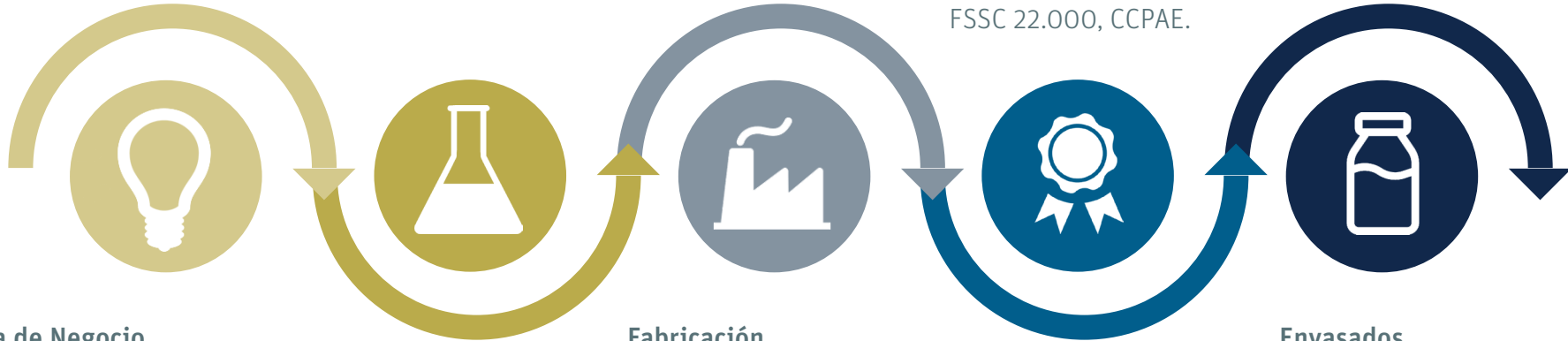

Idea de Negocio

Apostamos por la innovación y el servicio personalizado para conseguir productos diferenciales en el mercado del complemento alimentario.

Fabricación

Fabricamos los productos con los más altos estándares de calidad.

Envasados

Disponemos de una gran variedad de formatos para dar la máxima flexibilidad de envasado.



INSTANT PROCES fue fundada en 1998 con el objetivo de desarrollar y fabricar complementos alimentario para terceros (B2B). A día de hoy, somos especialistas en el desarrollo, fabricación y envasado de complementos alimenticios, dietéticos, deportivos, productos para veterinaria y nutrición infantil.

FÓRMULA FARMACÉUTICA

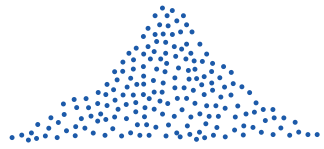

GRANEL



CÁPSULA



COMPRIMIDO

ENVASE



BLÍSTER



PILDORERO



BOTES

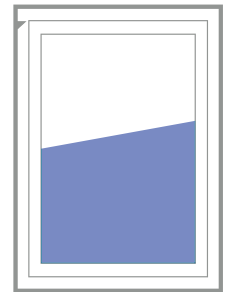

SOBRE



STICK



FLOWPACK

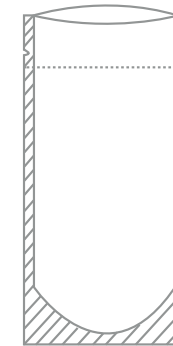

DOYPACK

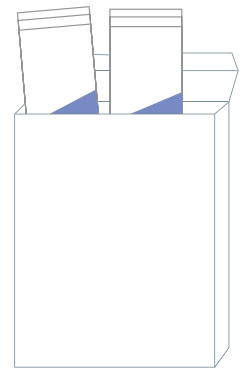

PACKAGING



CÁPSULAS

TAMAÑO 1

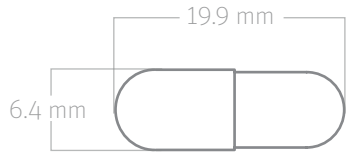

TAMAÑO 0

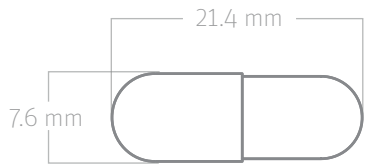

TAMAÑO 00

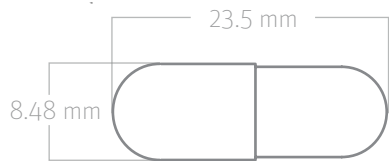

COMPRIMIDOS

OBLONGO I

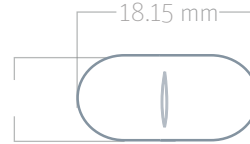

OBLONGO II

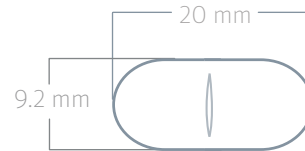

OVALADO

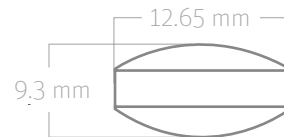

CÓNCAVO 10



CÓNCAVO 11

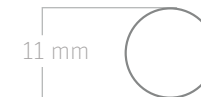

PLANO REDONDO

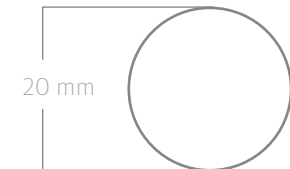

CÁPSULAS Y COMPRIMIDOS

Contamos con una variedad de formatos y medidas para nuestras cápsulas y comprimidos para definir el producto según sus características.

CÁPSULAS



COMPRIMIDOS



CÁPSULA 00

15 Cápsulas

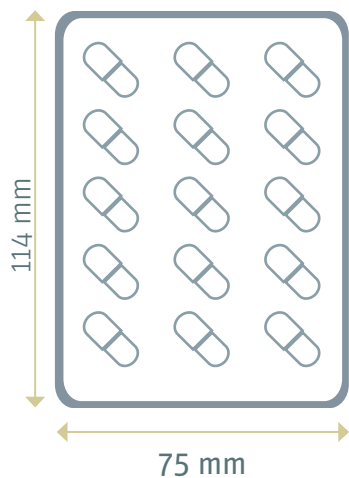

CÁPSULA 0 - 1

10 Cápsulas

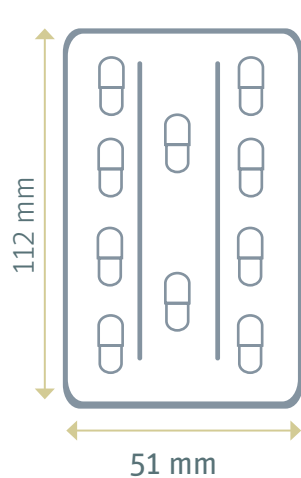

CÁPSULA 0

12 Cápsulas

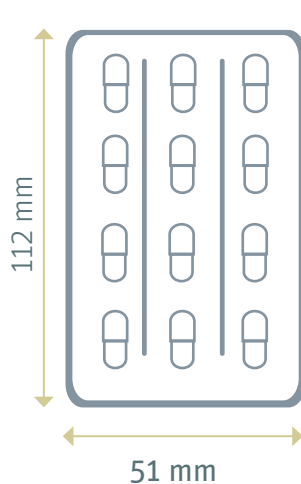

OBLONGOS

10 Comprimidos

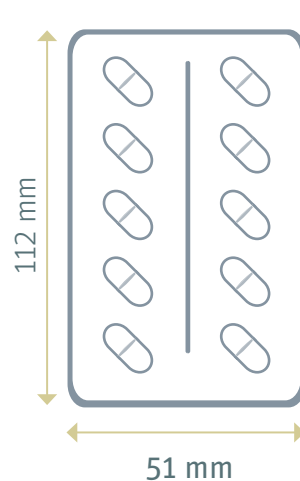

OVALADOS

15 Comprimidos

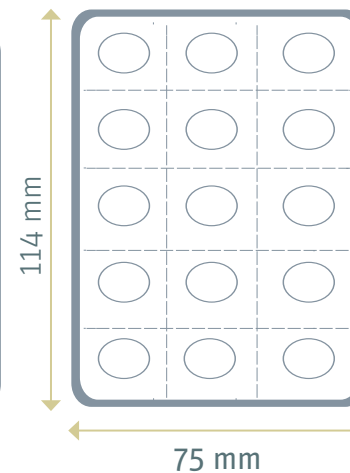

CÓNCAVOS

30 Comprimidos

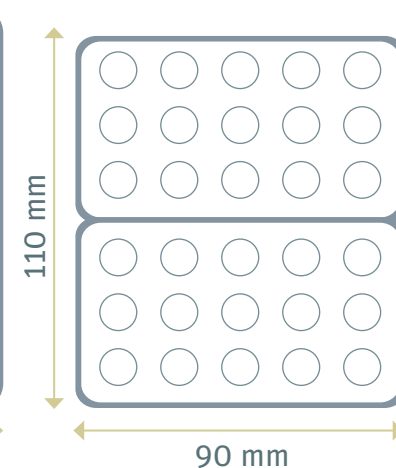

BLÍSTER

Los blísters son el envases de mayor calidad para comprimidos y cápsulas. Su material puede ser de PVPC,PVC y/ o aluminio según los requisitos idóneos de producto.

PILDORERO

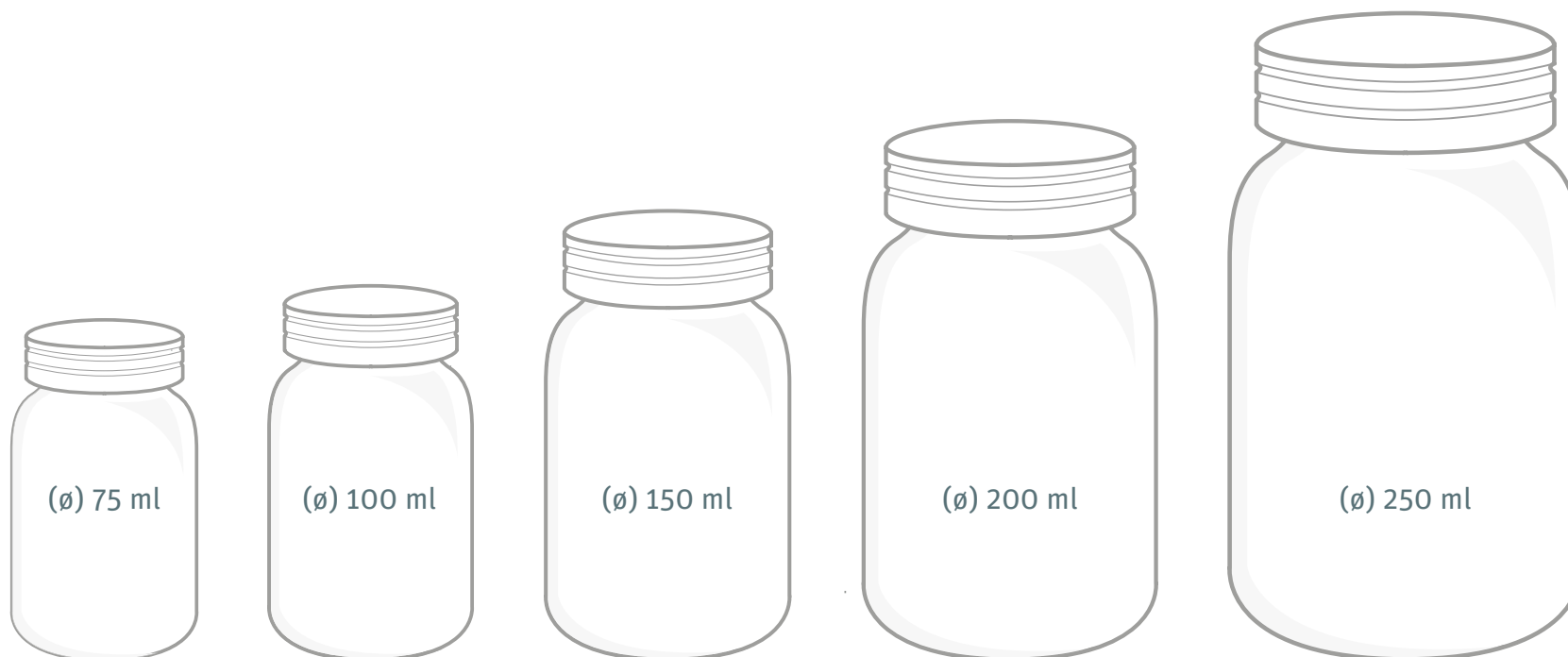

PILDORERO

Disponemos de pildoreros de volúmenes muy diferentes para envasar comprimidos y cápsulas según el número de unidades deseadas.

BOTE



CARTÓN

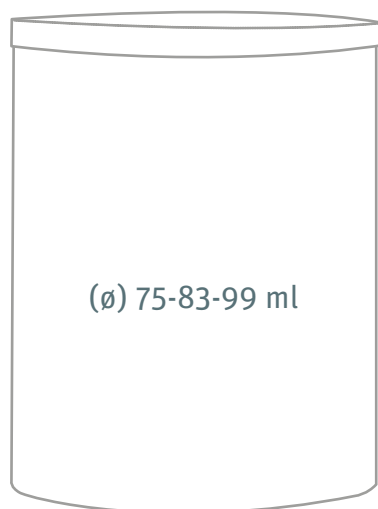

LATA

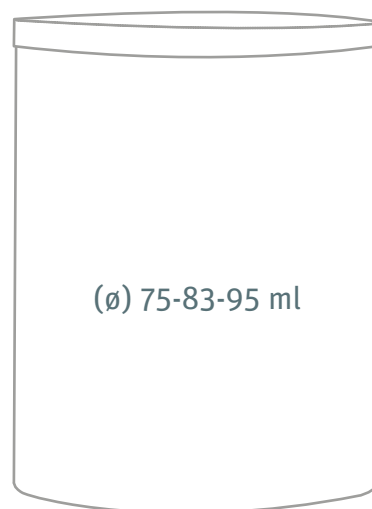

PET



BOTES

Tenemos tres líneas de envasado de granel soluble en bote de diferentes materiales: cartón, lata y PET.

SOBRE INDIVIDUAL

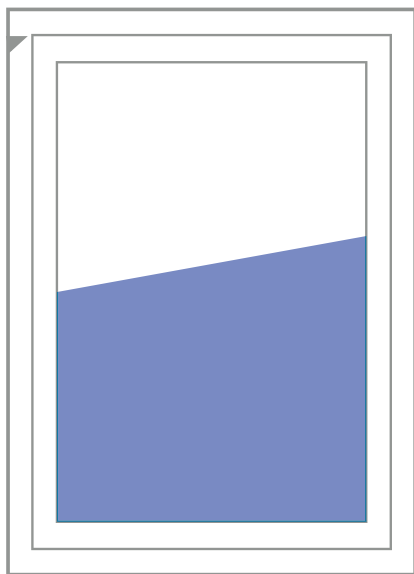

70 x 90 mm (entre 6 – 12 g)
65 x 80 mm (entre 3 – 6 g)

SOBRE DOBLE

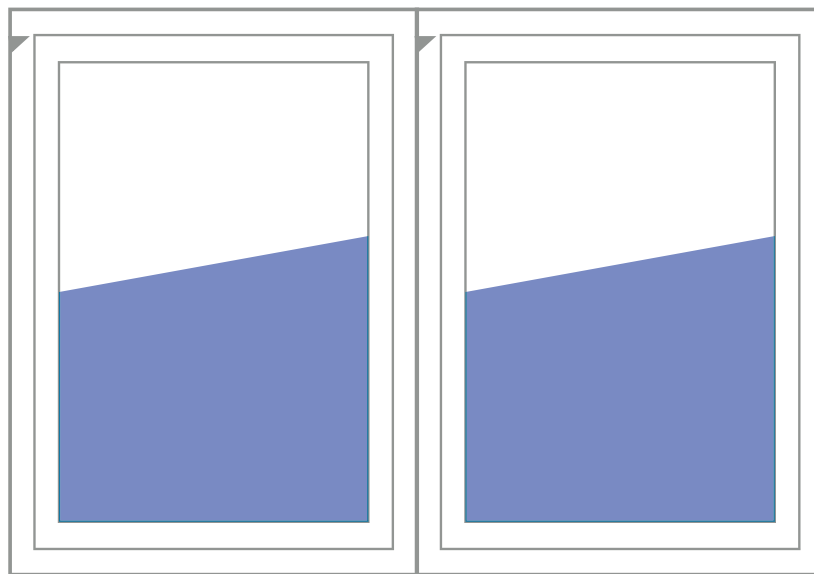

90 x 225 mm (entre 10 – 25 g)
90 x 140 mm (6 – 12 g)
70 x 100 mm (3 – 6 g)



SOBRES

Contamos con dos líneas de envasados de sobres con medidas muy flexibles, para ajustarnos a las dimensiones según cantidad y densidad de producto.

STICK

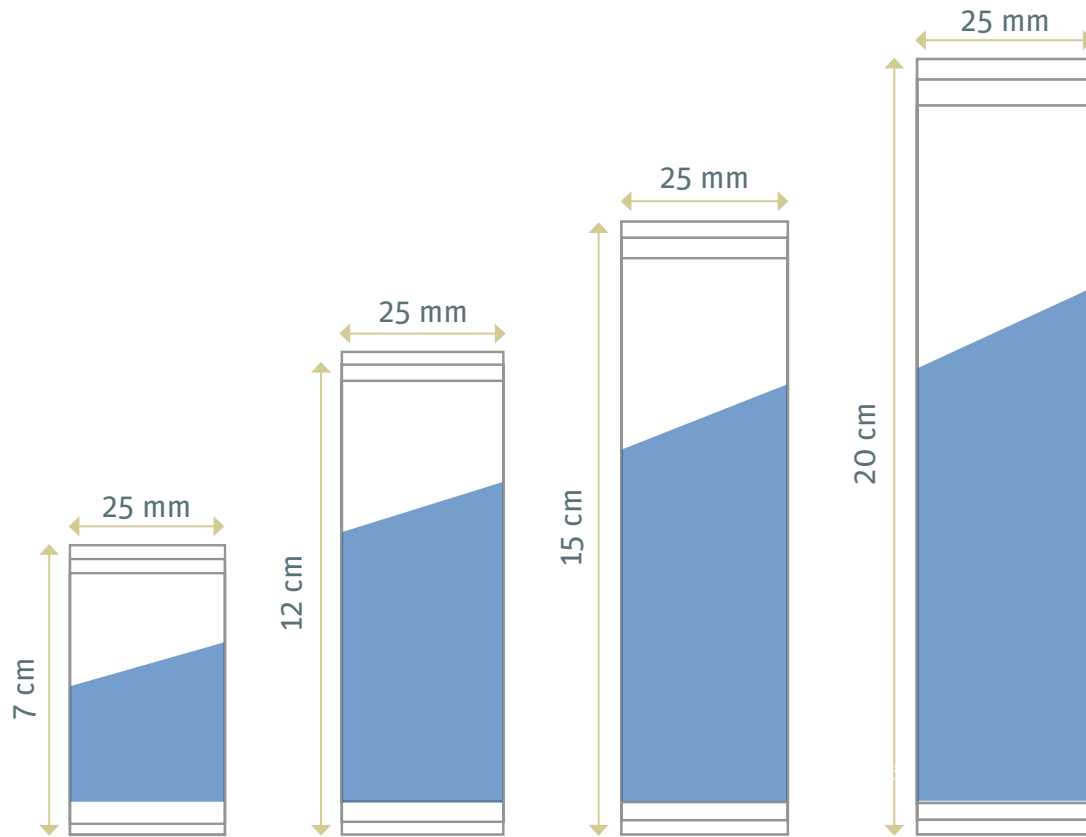

FLOWPACK



STICK Y FLOWPACK

Formato stick para envasar granel soluble y formato de flowpack como muestra del producto de referencia.

DOYPACK

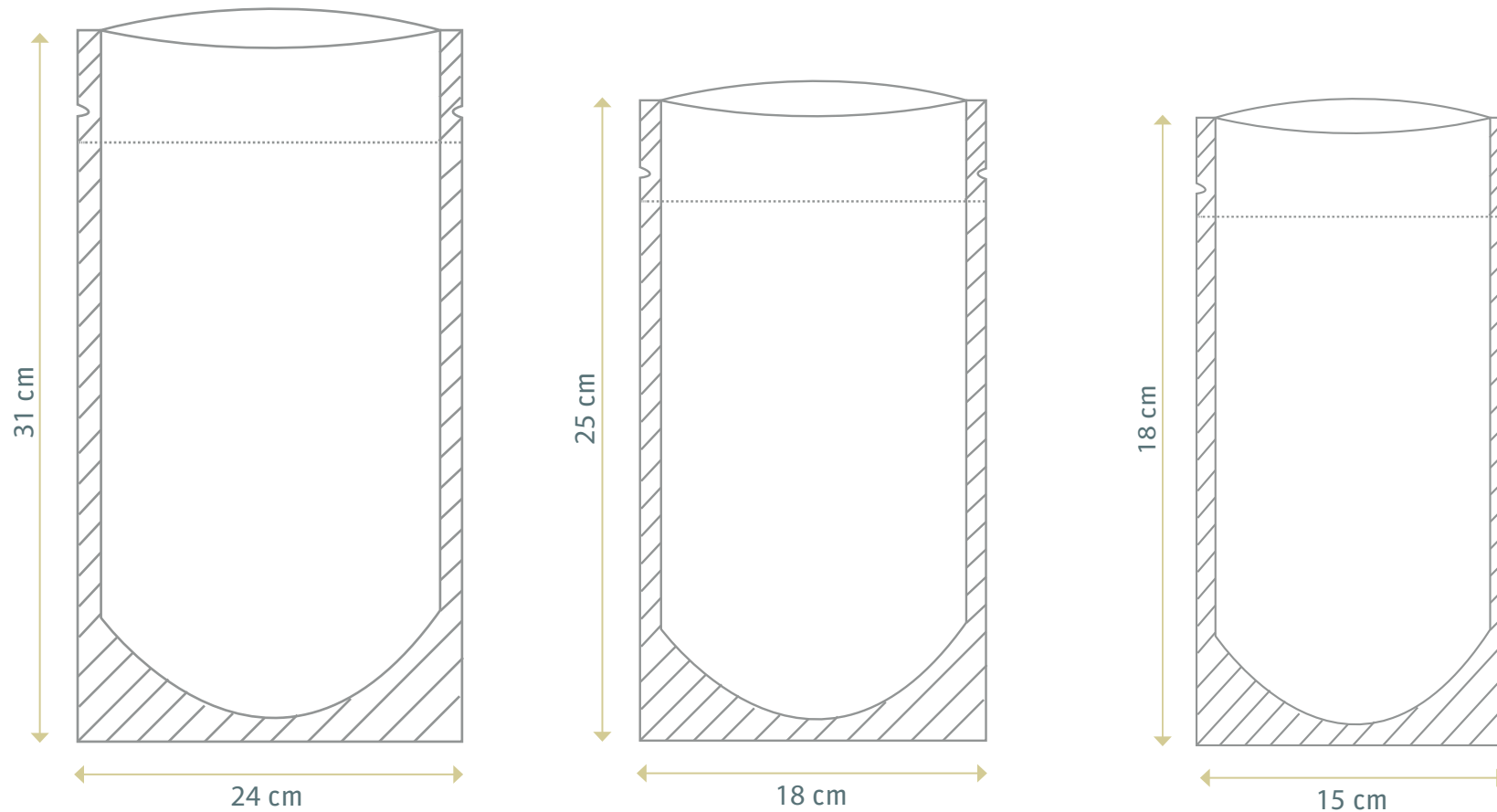

DOYPACK

Disponemos de una línea específica para envasar el granel en doypacks de infinitas medidas y materiales para obtener un producto con formato innovador y diferencial.

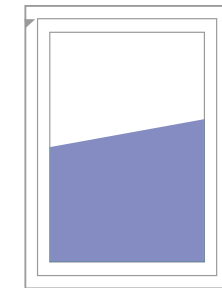
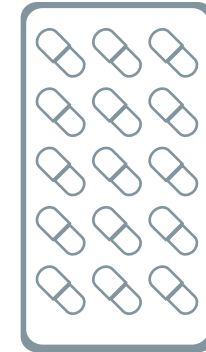
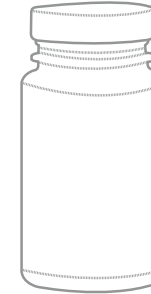

PACKAGING

Estuchamos tanto blisters como sobres y sticks para dar un servicio íntegro desde el desarrollo de producto final para ser comercializados directamente en el mercado.

INSTANT PROCES

Polígono industrial Valldoriolf
Carrer Alfred Nobel, 12
08430 La Roca del Vallès, Barcelona.

E-mail: info@instantproces.com

Teléfono: +34 937 32 60 00